

# Are Your UPS Specs

To make use of today's insulated-gate bipolar transistor technology, any older uninterruptible-power system

specifications are outdated. Here's a look at what might go into a state-of-the-art specification for UPS units with pulse-width modulated IGBTs.

# Obsolete?

By RICHARD H. SMITH, P.E.  
Contributing Reporter

**S**ignificant investments by two leading companies in pulse-width modulated (PWM)-controlled insulated-gate bipolar transistors (IGBTs) have demonstrated their value. Industry veterans have been working hard to catch up with these advanced designs.

One result is that engineers must now rewrite uninterruptible-power supply (UPS) system specifications to make better use of three-phase units with PWM-controlled IGBTs. Also, contractors and end-users must be aware of what the specifications really mean. Presented below are generic, but definitive specifications that take advantage of the technology's benefits.

This specification describes a three phase, on-line, continuous operation, solid-state uninterruptible power supply (UPS). The UPS shall operate as an active power-control system in conjunction with building electrical systems to provide conditioned uninterrupted power of a limited duration. The system shall consist of a converter, battery bank, solid-state inverter, automatic-static bypass-transfer circuit and integral maintenance-bypass circuit.

Next, engineers can expand the scope to include a simple statement of the UPS rating and the battery back-up time:

**System Operation** The UPS shall be designed to operate continuously at rated capacity as an on-line automatic system in the following modes:

**Normal.** The inverter continuously supplies AC power to the critical load. The converter converts commercial AC power

to regulated DC power, which then serves as the inverter input and, simultaneously, as a float charge input to the storage battery.

**Emergency.** In the event of a commercial AC power failure, the inverter shall derive its input from the system battery, thus providing uninterrupted power to the critical load. This transition shall be accomplished without any switching or coupling, and with no interruption of power to the critical load from either a failure or restoration of the commercial AC power.

**Recharge.** Subsequent to restoration of commercial AC power, the converter shall automatically reactivate and provide DC power to the inverter, simultaneously recharging the system battery. This occurs automatically and without interruption to the critical load.

**Bypass.** In the event that the UPS must be taken off-line due to an overload condition or UPS failure, the critical load shall be transferred to the bypass source via the static switch without interruption of power to the critical load. A paralleling wrap-around contactor shall be used to maintain the bypass source. The static switch shall only be utilized for automatic emergency transfers.

A retransfer from bypass to inverter shall be performed automatically in overload conditions. A retransfer shall be inhibited if satisfactory synchronization of the inverter and bypass is not accomplished. The use of the static switch shall not be required during the manual or automatic retransfer process, thus increasing reliability.

**Maintenance bypass.** The UPS system shall be equipped with an internal maintenance bypass switch (MBS) to allow safe

and reliable maintenance of the UPS. The bypass shall be of the make-before-break, "zero-energy" type to ensure maximum load reliability and personnel safety.

## Future Needs Determination

The design engineer and end-user must determine if future needs and available space allow for parallel operation to expand capacity for redundancy and high reliability.

Some companies promote field-upgradeable systems—where the UPS can be changed from 30 kVA to 50 kVA, for example. System life-cycle cost is quite high if the parallel or upgradeable approach is not used, since the initial wiring and switchgear must be rated for the higher load, which is a higher power rating. Conversely, if the upgrade does occur, it was an efficient, cost-saving idea. A highly restrictive specification from one supplier reads:

**Future expansion:** The UPS shall be capable of a field upgrade to allow parallel operation with additional UPS modules for increased capacity or for redundant operation. The parallel systems shall be capable of operation on a common DC bus or with a separate DC bus for each system module and shall provide proportional load sharing between all available modules. To provide a true fault-tolerant control system, any individual UPS module shall be capable of automatically assuming control of the entire system.

**Standard Features:** Transistorized PWM IGBT/intelligent power-module converter.

This is where the suggested descriptive wording for the specification varies with



the manufacturer. Words like “converter,” “delta inverter” and “intelligent power module,” or IPM, have been used to replace the basic word “inverter.” For the engineer and the end-user, however, the key here is that the system include:

- Digital-signal processing (DSP) using PWM for direct-digital-control (DDC) of all UPS control and monitoring functions.
- Transistorized PWM IGBT intelligent inverter for output.

### **Sweeping Changes**

Using the IGBT in both the converter and inverter, essential to any modern UPS specification, represents the most significant change in UPS technology in 20 years. Old specifications that contain words like “ferroresonant,” “six pulse” and “twelve step” are obsolete when interfacing with today’s complex computer and telecommunications systems.

Use of IGBTs in UPS units follow the same pattern as that for other rectifiers. When switched on, the IGBT has very low resistance between the collector and the emitter. As so many electrons flow through the bipolar base region, the base’s conductivity increases 1,000 times, which keeps power loss at a minimum.

It is important that the IGBT has a higher operating current density than its bipolar transistor and metal-oxide-semiconductor field-effect (MOSFET) components. The currents of the MOSFET and the bipolar transistor’s emitter collector combine to produce an operating current

density twice their individual capabilities. Additional standard features include:

- Output isolation transformer.
- Fault memory and diagnostics.
- Menu-controlled operation.
- Active control of output voltage distortion.
- Automatic input current walk-in.
- Remote operation.
- Automatic UPS restart and load pick-up after the battery is depleted and the utility power is restored.
- Internal DC disconnect and fuse protection.
- Remote and local emergency power off (EPO).

### Codes and Standards

Safety codes require the following EPO buttons at the exit door to ensure that the UPS battery output does not create unwanted high-power output during a fire:

- Input AC disconnect and fuse protection.
- Internal maintenance bypass switch.
- Remote monitor panel (optional).
- Input isolation transformer (optional).

The listing of applicable standards for UPS systems varies greatly. Government specifications will list not only applicable technical standards, but also will list many safety and human-betterment standards:

- Underwriters Laboratories (UL) 1778 and Canadian Standards Association (CSA) 22.2 (cUL equivalent).
- International Electrotechnical Committee (IEC), Semiconductor Converter Standards.
- International Organization for Standardization (ISO) 9001 Quality Assurance program.
- Local applicable specifications.

Reference to the local specifications forces the installer to review city and state

## Key Elements in a State-of-the-Art Spec

The following requirements must be included in a state-of-the-art UPS specification to take advantage of the latest in technological advances:

- The input and output must include an intelligent PWM-controlled IGBT package.
- Efficiency of 92 percent or greater.
- Input power factor of 0.98 or better.
- Upstream reflected harmonics of no greater than four percent at full load, and six percent at half-load, without the use of extensive capacitor banks.
- Web/SNMP software.
- Dial-up management software and hardware.
- Emergency power off.
- Off-hours start-up, if required.
- Clearly defined service and warranty.

## About IGBTs

Using insulated-gate bipolar transistors (IGBTs) in uninterruptible power-supply (UPS) systems can eliminate the majority of harmonics problems associated with silicon control rectifiers (SCRs). With the pulse-width modulated (PWM)-controlled IGBT UPS, harmonics can be reduced to between 4 percent and 7 percent without custom input filters and regardless of load from 50 percent to 100 percent.

With the added benefit of low-input power factors—0.98 or greater—the system is utility- and generator-friendly, permitting a generator size only 1.3 percent greater than the UPS rating, rather than the 200 percent required to properly perform with the traditional UPS that has high harmonics—13 percent to 26 percent—and low power factor—0.9.

A side benefits permitted by the IGBT in both the converter and inverter is extended battery life since step loading is no longer a drain on the batteries.

The system designer using the PWM IGBT UPS can also reduce the size of input conduits, switchgear, transformers and generators in UPS or generator applications. Installation labor costs are also lower.

For more information on IGBTs, see "Power Quality Vista Looks Good Thanks to IGBTs," in the Fall 1998 issue of *Pure Power*.

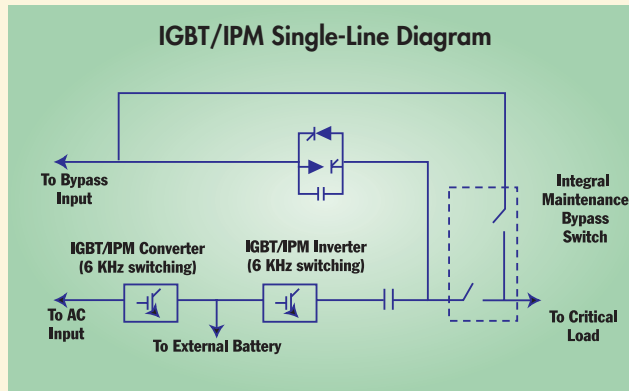

TOP: An on-line double-conversion system configuration for an IGBT/IPM, including a transistorized converter and inverter.

LEFT: Shows IGBT/IPM three-phase boost-converter topology for active reduction of reflected-input current without the use of a passive-resonant LC filter. Inverter also uses IGBT/IPM technology.

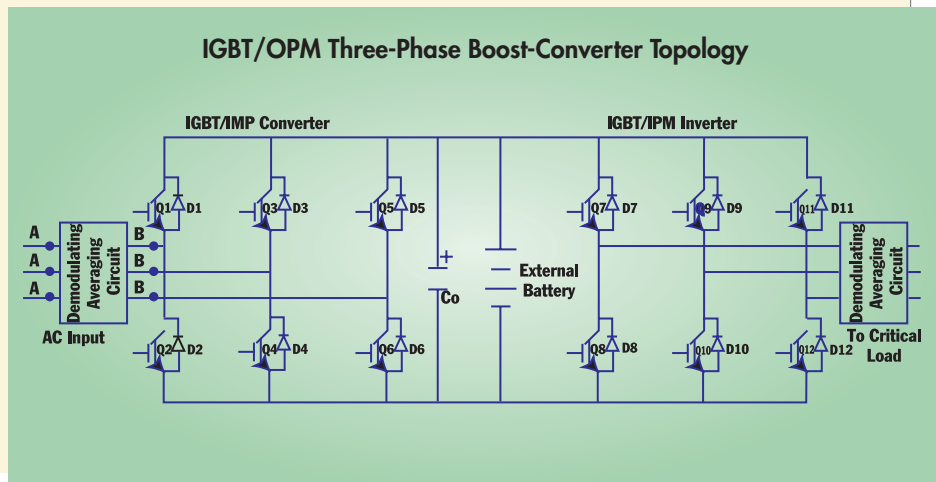



## Writing New UPS Spec

**W**hen drawing up a new uninterruptible power-supply specification to accommodate pulse-width modulated (PWM)-controlled insulated-gate bipolar transistors (IGBTs), it's important to be aware of the following points:

- **Start-up.** In some new installations, UPS start-up can occur during normal business hours. In existing facilities, this is seldom the case. Off-hours start-up is often a disagreement issue between the electrical contractor, supplier and owner. It would be helpful to have this clearly required by the specification.

- **Warranty.** This can be a tricky issue. One company offers warranty, service and start-up in 17 different options, which can totally confuse a UPS end-user. Most plans include one-, three- and five-year options. Recently, one government agency was considering ordering a start-up, service and warranty package for five years that was greater than the price of the new UPS and batteries.

Care must be taken to ensure that the warranty and service packages include both the UPS and batteries. Some of the new five-year warranty packages that include the UPS and batteries are a great buy—especially if the new batteries are of the five-year type. Some batteries will actually fail in a three- to four-year period.

- **Service.** With some of the larger UPS installations, or where several UPS units exist at one site, the owner should consider sending a representative to the vendor service schools.

- **Panel display design.** Since UPS systems have, in many cases, become commodity items, the custom design of panel displays are no longer

practical. Nearly all UPS system manufacturers offer relay contacts, battery monitoring, status screens and computer interface. The specification should be open to what the user wants to accomplish, rather than the specific technique to provide the information.

codes that may have been unfamiliar to the designer, but are not overlooked by local electrical inspectors.

The installer must review city and state codes unfamiliar to the designer.

### Specifying Key Values

A state-of-the-art UPS specification needs a section called "Performance Characteristics" to establish a measurable set of values to serve as a quality baseline. This is where the engineer or end-user can firmly establish those specifications that are most significant to the application:

#### Performance Characteristics:

- Power rating:     kVA/KW at 0.8 lagging.
- Input voltage:     volts, 3-phase, 3-wire.
- Input voltage range: +10 percent, -15 percent.
- Input frequency: 60 Hz +/-5 percent.
- Input power factor: 0.98 lagging, minimum at 100 percent load; 0.95 lagging, minimum at 50 percent load without additional harmonic filters.

The values selected separate the old UPS specifications from the new IGBT units, so this section is critical to the specification. Older product lines required a generator twice the size of the UPS to overcome the negative effects of low-power factors and high reflected harmonics. The new units require only a 1.3:1 kVA to kVA relationship.

Manufacturers that produce the PWM-controlled IGBT power modules can actually produce unity power factor equipment. This characteristic and the reflected harmonic value stated below are those performance features that permit the new family of UPS equipment to be compatible with generators.

- Reflected input current total harmonic distortion (THD): 3 percent maximum at 100 percent load, 6 percent maximum at 50 percent load.

Low THD and high power factor also have value when connected directly to the utility. The result is a lower utility bill. Other key performance characteristics include:

- Nominal output voltage:     volts, 3-phase, 4-wire.
- Nominal dynamic-voltage regulation: +/-1 percent for unbalanced loads.
- Voltage transient response:
  - a. +/-3 percent for a 50-percent load step.
  - b. +/-5 percent for a 100-percent load step.
- Output voltage-harmonics distortion:

- a. 2-percent THD maximum with 100-percent linear load.
- b. Typically 4-percent THD maximum with 100-percent nonlinear load.

- Output overload capability:
  - a. 125 percent for 10 minutes while maintaining voltage regulation.
  - b. 1000 percent for one cycle while using the bypass for fault clearing.
- Full load efficiency: greater than 92 percent.

### Define the Environment

One section of the specification must clearly define the environment in which the UPS will operate. Most UPS equipment will function satisfactorily in temperatures from 0°C to 40°C. However, they will have an extended life if operated with a temperature range of only 20°C to 30°C.

Of course, units could sit on the shipping dock in temperatures from -20°C to 70°C. Relative humidity could be in the 5 percent to 95 percent range, noncondensing; the recommended operating range is typically 30 percent to 90 percent.

The extended temperature and humidity ranges listed above would not be suitable for the batteries, however. Problems have occurred when designers or end-users have ignored the storage, handling and installation of batteries. Simple items like excessive dust on the top of the batteries can reduce battery life by migration of DC, over long periods, between the posts.

A simple rule of thumb is that battery life is halved for every 10 degrees above 77°F.

### Software Issues

The Web/SNMP management card is provided as part of the base price of most UPS systems. This feature enables the full management of the UPS protective networking equipment from power-related events using a browser. Network administrators can fully manage and control the UPS through open industry standards.

Other key functions include:

- Power shutdown.
- Environment monitoring.
- Out-of-band management.
- Remote power off. ⚡

